

SUPERCHANGER®

PLATE & FRAME
HEAT EXCHANGERS

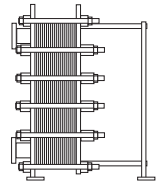

APPLICATIONS FOR HVAC SYSTEMS

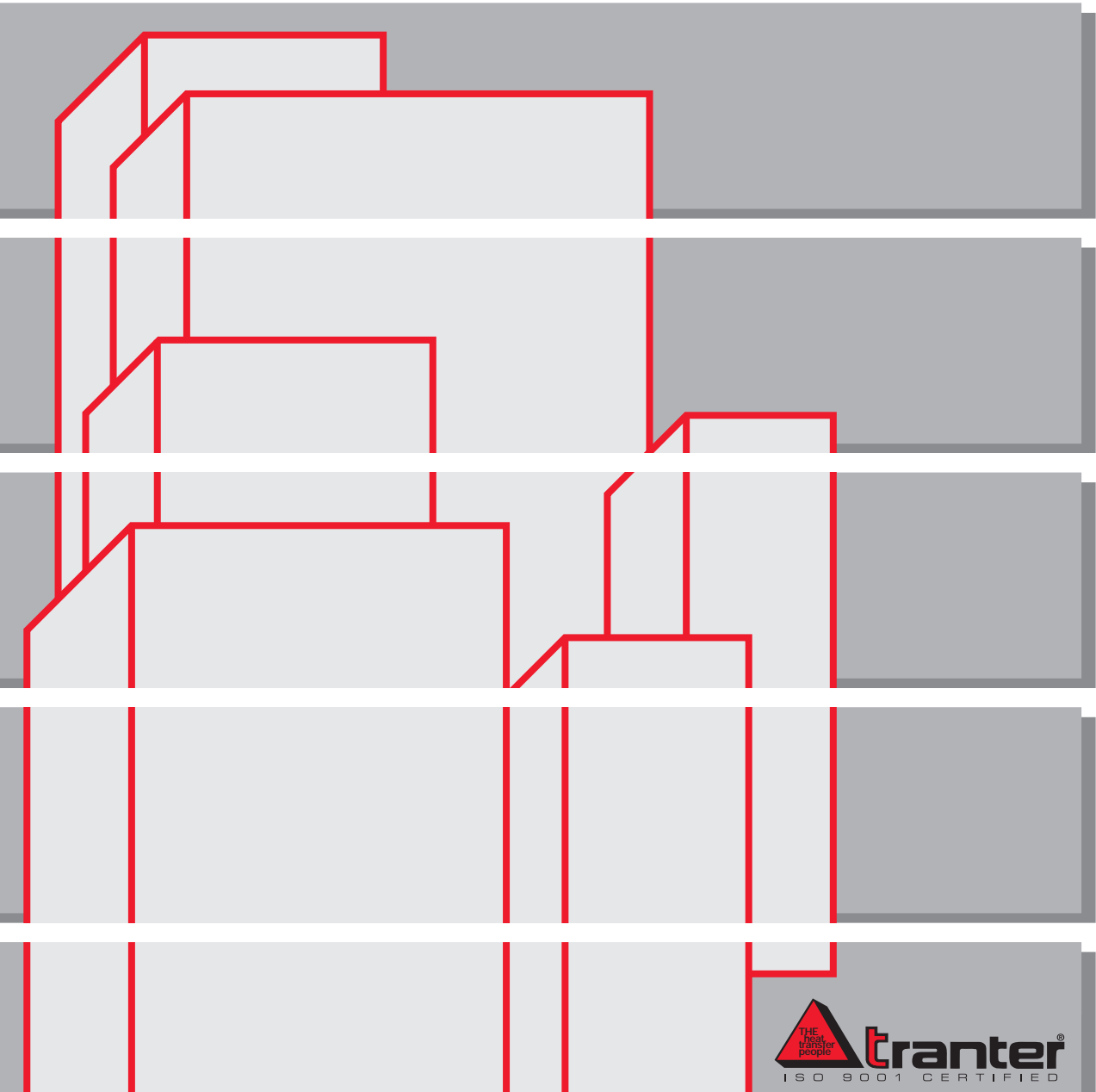

SUPERCHANGER[®]

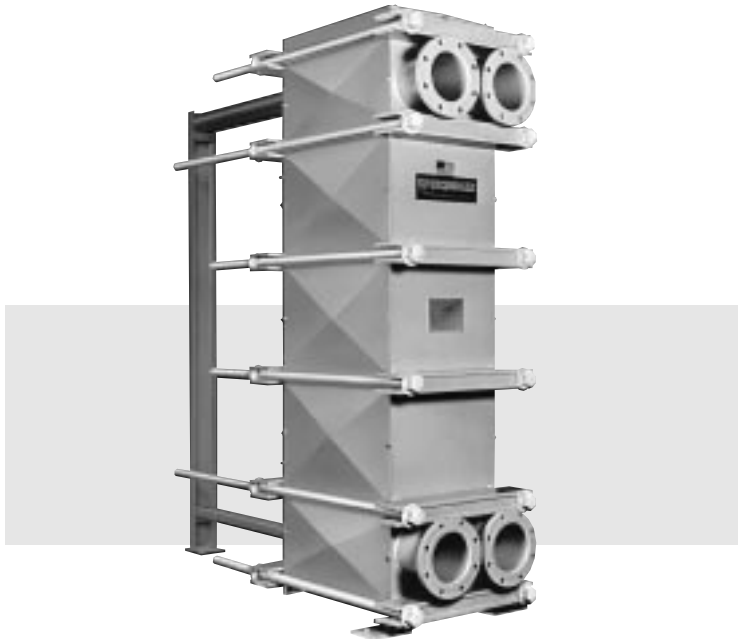

- Highly Efficient • Low Cost • Expandable Capacity
- Guaranteed Performance • Proven in Numerous Applications
- Fast, Accurate Computer Sizing • Made in the U.S.A.

SUPERCHANGER CONDENSED SPECIFICATIONS

The data on this page provides basic condensed engineering information. All selections are calculated by computer to provide the best plate size and design fit for each specific application. More complete literature and specifications are available on request.

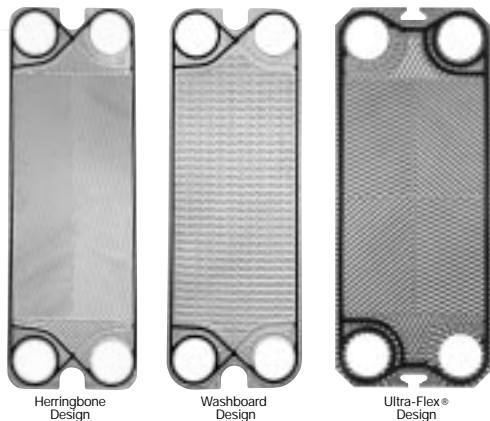

Pressure Rating: Up to 400 psig operating pressure

Maximum Temperature: 366°F

Heat Transfer Coefficients: Greater than 1000 Btu/hr ft² °F

Heat Transfer Surface: Up to 20,000 ft² per unit

Plates: SUPERCHANGER plates are fabricated from virtually any metal that can be cold-worked, including stainless steel (types 304, 316, 317, etc.), titanium, Monel, nickel, alloys 825, 20Cb-3, B-2, G, C-276 and others.

Frames: Carbon steel with baked epoxy enamel paint, side bolts and shroud.

Nozzles: 150 lb. rated flange type, with other options available.

Gaskets: Nitrile, Ethylene Propylene, Viton, Neoprene, Hypalon, Butyl, Teflon-encapsulated NBR and others available.

Optional Extras: Connecting frames. Threaded or clamp type nozzles. Stainless steel tightening bolts. ASME Code Stamp.

Trial Units Available: SUPERCHANGER units are available on a trial basis for in-plant testing and evaluation. Contact your Tranter representative for information on the SUPERCHANGER Trial Unit Policy.

APPLICATIONS FOR HVAC SYSTEMS

FUEL AND MONEY SAVINGS

Adequate heating and cooling when temperatures rise and fall. The proper flow of air. Both are critical factors in the efficiency of an institutional or commercial building. When a structure's occupants are comfortable, productivity increases. But the costs involved in providing optimum comfort can adversely affect the total profitability of the operation.

Heating, ventilating and air conditioning (HVAC) is expensive and, with energy costs promising to continue their climb, the 1990s are testing the energy conservation efforts of us all.

Outstanding strides have been made in the past decade to make the workplace a more energy-efficient environment. Today, in many institutional and commercial buildings, computers control temperatures, lighting requirements and power usage. The necessity for greater energy efficiency in institutional and commercial heating and cooling has also required significantly new approaches in HVAC system design.

In many HVAC systems, the traditional shell-and-tube heat exchanger is giving way to the SUPERCHANGER plate and frame heat exchanger because of its greater efficiency and flexibility. Most shell and tube heat exchangers are designed for an 8-10°F approach temperature, whereas a SUPERCHANGER unit regularly operates at a 1-2°F temperature approach.

The savings are outstanding. In space requirements. In maintenance. In initial investment. And especially in fuel outlays. We'd like to show you how, why and where the SUPERCHANGER heat exchanger is finding application in HVAC systems.

THE UNIT DEFINED

The SUPERCHANGER unit is a plate and frame heat exchanger that provides highly efficient liquid-to-liquid or steam-to-liquid heat transfer. It consists of a series of gasketed, embossed metal plates bolted together between end frames to form channels through which hot and cold media flow. Hot medium flows on one side of the plate, while cold medium flows countercurrently on the other. The plate between the two media provides the means to transfer heat from one to the other.

HIGH HEAT TRANSFER EFFICIENCY

The unmatched heat transfer efficiency of the SUPERCHANGER plate and frame heat exchanger is due to the turbulent flow created by the corrugated plates. As

turbulence increases, so does the amount of heat transferred from one medium to the other. Resulting are heat transfer coefficients from two to five times greater than those achieved by other means of heat transfer, such as the shell-and-tube heat exchanger.

LOW FOULING

Fouling is minimized in a SUPERCHANGER plate and frame heat exchanger for the same reason its heat transfer efficiency is so high. Turbulent flow, coupled with the velocity profile, causes deposits from dirty media to be continually washed from the unit's heat transfer surfaces. Fouling factors for the SUPERCHANGER plate and frame heat exchanger are about one-tenth of those for shell-and-tube exchangers.

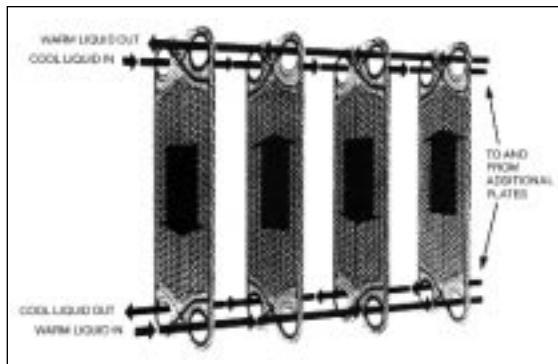

so high. Turbulent flow, coupled with the velocity profile, causes deposits from dirty media to be continually washed from the unit's heat transfer surfaces. Fouling factors for the SUPERCHANGER plate and frame heat exchanger are about one-tenth of those for shell-and-tube exchangers.

EASY TO MAINTAIN

SUPERCHANGER plate and frame heat exchangers are easy

to maintain. Low fouling rates result in reduced cleaning requirements. Units can either be chemically cleaned in place, or quickly disassembled by hand, cleaned and put back into operation. Regardless of the method used, cleaning time is minimal when compared to that required for shell-and-tube units.

MADE IN U.S.A.

SUPERCHANGER units are made in the U.S.A. The benefits are many—from a substantially lower initial cost, to easier availability, faster delivery and better service. Because SUPERCHANGER units are manufactured in the United States, the user is assured of greater savings of money and time. And fewer headaches.

MORE ADVANTAGES

Compared to other heat exchangers, such as the shell-and-tube type, SUPERCHANGER units require much less floor space, are lighter in weight, cost less, and can be expanded to handle increased heat loads simply by adding more plates. A detailed comparison is provided on the back cover of this brochure.

VARIED HVAC APPLICATIONS

Because of the advantages detailed here, SUPERCHANGER plate and frame heat exchangers can handle a variety of HVAC system applications. From cooling tower isolation to "free cooling" to waste heat recovery and solar collection. SUPERCHANGER design flexibility and close temperature approach make it ideal for improving system efficiency, and saving energy and money. An idea of how SUPERCHANGER plate and frame heat exchangers are now being used successfully is provided in the following sections, separated into heating and cooling applications.

COOLING APPLICATIONS

COOLING TOWER WATER CIRCUIT ISOLATION

Cooling tower water is generally contaminated with solids and corrodents because it is open to the atmosphere. It is undesirable to pump this water through expensive chillers or unitary heat pumps because of plugging and corrosion problems. SUPERCHANGER heat exchangers are regularly installed between the cooling tower and the cooling equipment. SUPERCHANGER units are easily cleaned and have corrosion-resistant plates. Further, these exchangers are more efficient than shell-and-tube units because of their close temperature approach characteristics.

System A1 is a design with a central chiller and air handling units.

System A2 is a design using individual unitary heat pump units.

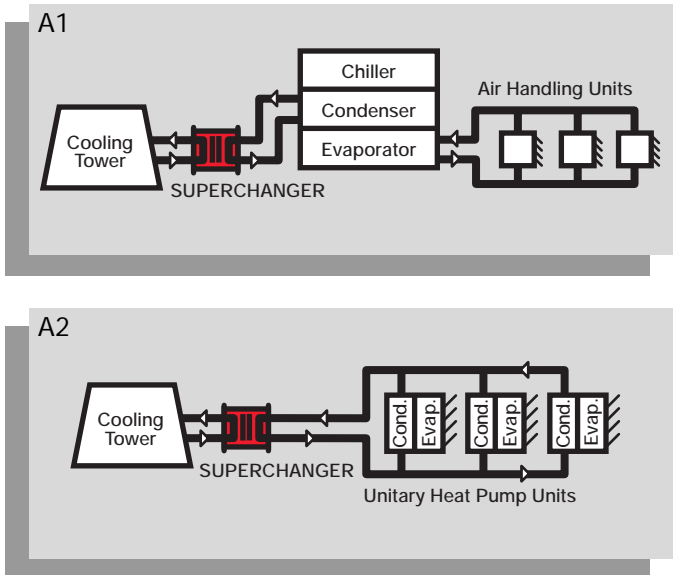

"FREE COOLING" DURING MODERATE TEMPERATURES (CHILLER BYPASS)

In some sections of North America, there are many periods when the wet bulb or ambient temperature is low enough to provide adequate cooling using cooling tower water directly. The diagram shows a SUPERCHANGER heat exchanger in a bypass circuit so that the chiller can be shut down whenever such conditions exist. This system results in sizable savings when climate and wet bulb conditions are favorable.

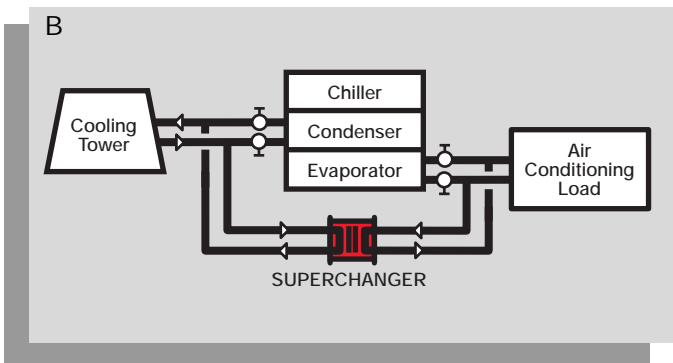

ISOLATION AND "FREE COOLING" (COMBINATION OF A AND B)

When a cooling tower isolation SUPERCHANGER heat exchanger (as in A above) is included, the chiller can be bypassed with valves and piping alone to take advantage of "free cooling."

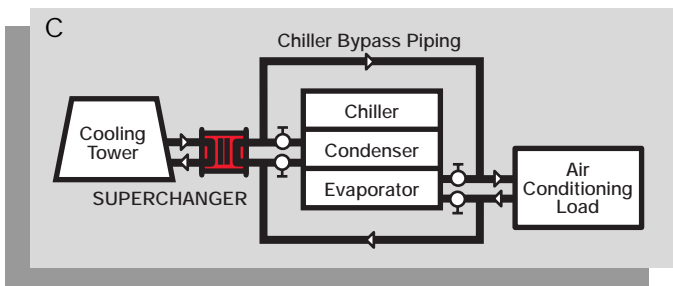

ISOLATION OF RIVER, LAKE, WASTE OR SEAWATER COOLANTS

Even though filters are normally used, river, lake, waste or seawater normally contain solids that may be corrosive. The use of a SUPERCHANGER heat exchanger between the pond, etc. and the chiller will protect the equipment. SUPERCHANGER units have corrosion-resistant plates and are easily cleaned.

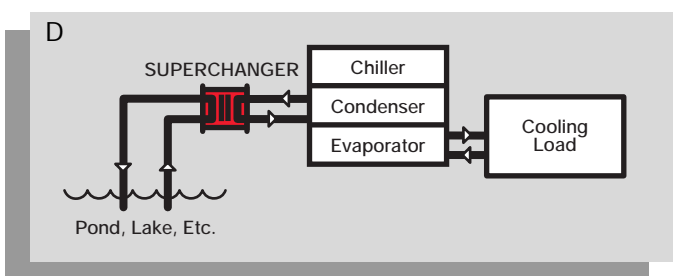

STATIC HEAD ISOLATION IN TALL BUILDINGS

Tall buildings can be divided into several zones for chilled water piping. By using the several zones with SUPERCHANGER heat exchangers at different elevations, the pressure from the static head is eliminated. This allows the use of lower pressure piping and valves for cost savings. Further, the close approach temperatures possible with SUPERCHANGER units result in superior efficiency as compared to a shell-and-tube system.

Arrangement E1 shows the exchangers in series. This reduces the pressure head in all piping, but a small temperature gradient will occur. Typical fluid temperatures are shown for this system.

Arrangement E2 shows the exchangers in parallel. This requires higher pressure piping for the mains, but supplies the same chilled water temperature to all zones. Lower pressures exist in distribution piping in each zone.

Similar conditions exist when the chiller is located on the roof, and also with boilers for heating.

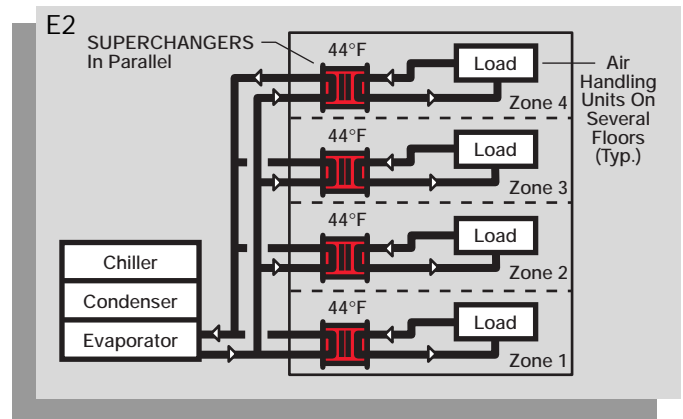
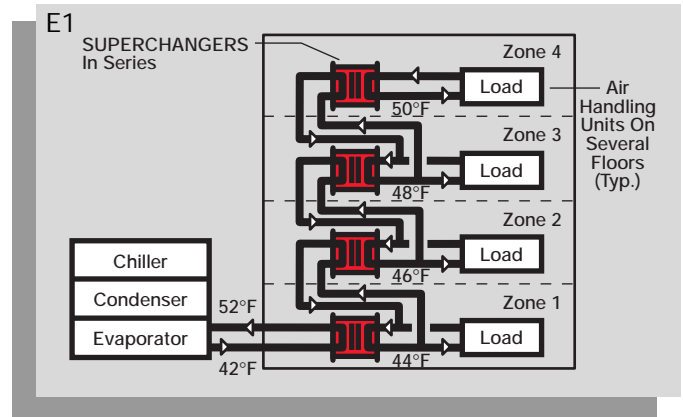

THERMAL STORAGE—ISOLATION OF STORAGE TANK

Whenever the air conditioning load is low, such as at night, it is becoming increasingly common to utilize the extra chiller capacity to cool water in a storage tank for use later when the load is heavy. Water used in these storage tanks generally develops a high solids content or may be otherwise contaminated. A SUPERCHANGER heat exchanger is ideal to isolate this water from the rest of the system. This arrangement also may be applicable for heating systems.

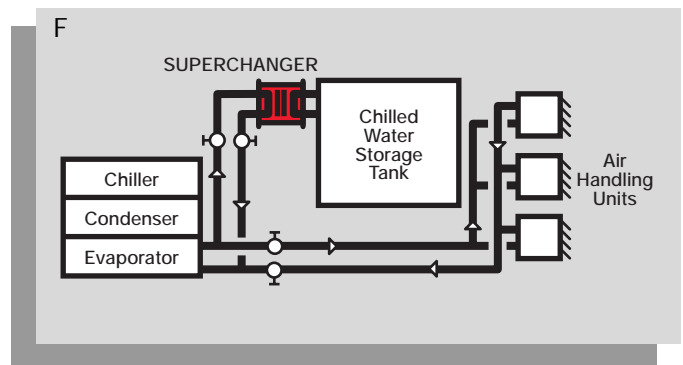

WATER SOURCE HEAT PUMP PRECOOLER WITH ISOLATION

The return water from the air conditioning load can often be cooled considerably by use of the water source directly. This reduces the load on the chiller. The isolation SUPERCHANGER unit prevents contamination of the condenser by unclean water.

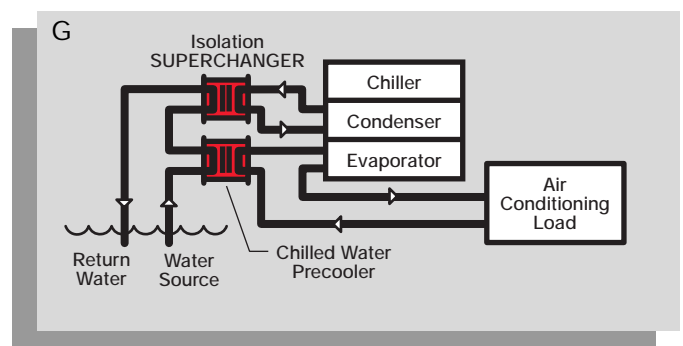

HEATING AND HEAT RECOVERY APPLICATIONS

HEATING POTABLE HOT WATER (INSTANTANEOUS HEATER)

SUPERCHANGER units are excellent for heating potable water with low pressure steam or hot water. The stainless steel plates provide a clean, smooth surface for use with potable water. Very high heat transfer rates are obtained, thus allowing a smaller, more compact water heater than would normally be required.

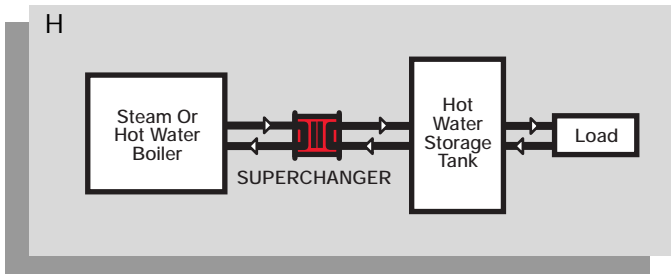

WASTE HEAT RECOVERY FROM CONDENSER WATER

Water going to a cooling tower from a condenser is frequently warm enough to be useful for preheating make-up water or winter air. A SUPERCHANGER unit can recover this "free heat," when available, for reduced heating costs.

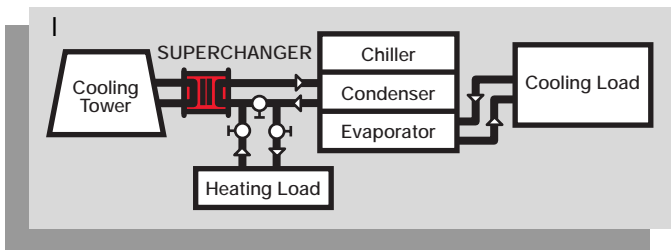

WATER SOURCE HEAT PUMP ISOLATION

Heat pumps are being used in increasing numbers as energy costs go up. Water used as the heat source, or heat sink for such systems, is generally contaminated with solids or scaling tendencies, etc. The SUPERCHANGER heat exchanger, with its close temperature approach characteristics, efficiently isolates this water from the heat pump system exchangers.

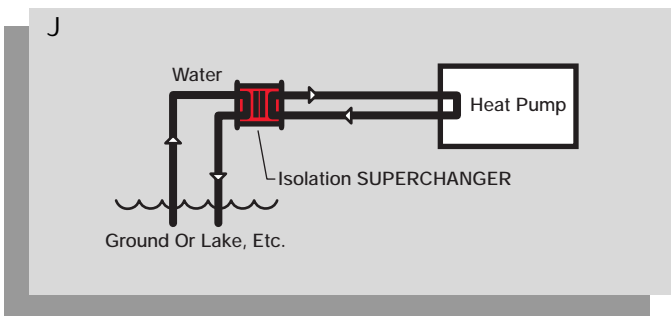

WASTE HEAT RECOVERY FROM CONDENSATE OR BOILER BLOW DOWN

Condensate frequently requires cooling so that it will not flash. Also, in some instances, condensate is not returned to the boiler. In both situations, heat can be recovered with a SUPERCHANGER heat exchanger to save fuel. Heat is also frequently recovered—and savings realized—from boiler blow-down as shown.

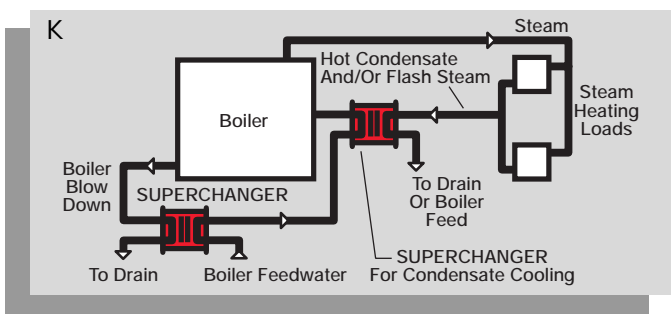

SOLAR COLLECTOR FLUID ISOLATION

Every closed loop solar collector system that uses glycol or other non-freeze fluids requires a heat exchanger to isolate this fluid from the water being heated. SUPERCHANGER heat exchangers, with their inherent close temperature approach and high heat transfer rates, are considerably more efficient than the coil-in-the-storage-tank method.

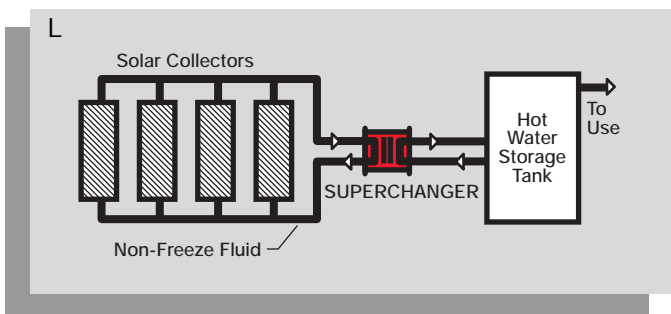

WASTE HEAT RECOVERY FROM OVERHEATED AREAS

A computer room is only one example of hot spaces requiring regular cooling. Water used for this cooling frequently exits warm enough so that energy can be recovered. This is more practical with a SUPERCHANGER unit, because of its close approach temperatures, than with a shell-and-tube system.

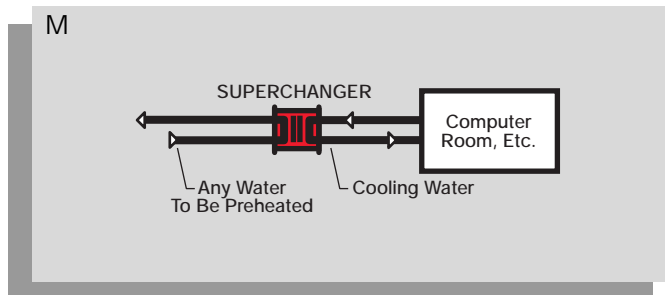

GEOHERMAL HEATING ISOLATION

The use of geothermal energy is increasing where it is available. The water and steam from the ground is generally dirty and corrosive. SUPERCHANGER plate and frame heat exchangers, with their corrosion-resistant plates (metals as specified) and low fouling tendencies, are ideal to transfer the heat to a clean water circuit.

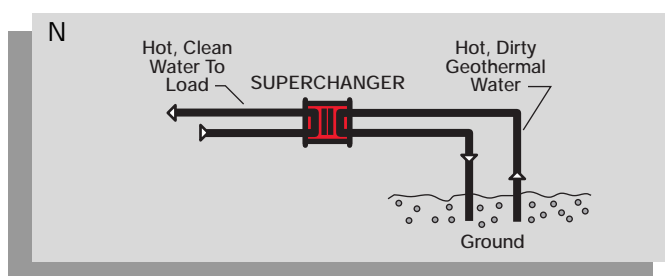

DISTRICT OR ZONE HEATING BUILDING ISOLATION

This type of heating system may become more common in North America as new designs incorporate more heating economies. A central boiler for several buildings can be more efficient than a small boiler in each building. With this district heating system, a small SUPERCHANGER unit in each building transfers the heat from the central boiler to potable water loops which circulate through the individual buildings.

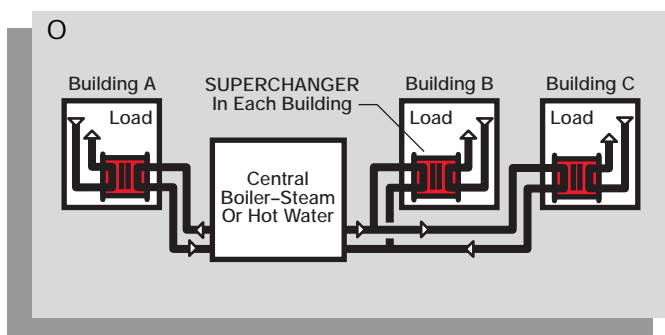

HEATING WATER/GLYCOL FLUIDS FOR SPACE HEATING, ETC.

There have been many problems with heating coils freezing in cold weather when a pump or steam supply fails. It is becoming increasingly common to use a non-freeze water/glycol heating medium in such conditions. These solutions are ideally heated with SUPERCHANGER units. Typical uses are for heating underground garages and for perimeter heating near ground floor doors that are opened frequently.

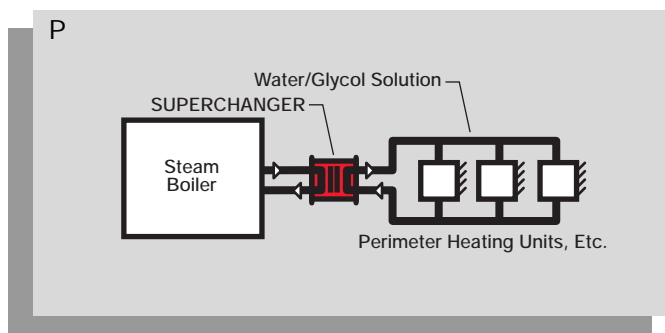

NOTE: THE DIAGRAMS SHOWN HERE ARE PURPOSELY BRIEF: NO ATTEMPT HAS BEEN MADE TO SHOW ALL THE VALVES, CONTROLS AND PIPING THAT MAY BE REQUIRED. IN MOST SYSTEMS, ALL PIPING ACTUALLY IS FROM THE SUPERCHANGER FIXED FRAME. THIS FACILITATES OPENING THE UNITS WHEN REQUIRED WITHOUT DISASSEMBLING PIPING.

SUPERCHANGER OUTPERFORMS SHELL-AND-TUBE

SUPERCHANGER heat exchangers require much less space than shell-and-tube units. They can pack greater than 20,000 sq. ft. of super efficient heat transfer surface in a single unit with flow rates up to 25,400 gpm. They provide greater flexibility; are more easily cleaned; experience much less fouling; have no interleakage; are lighter in weight; and cost less.

Most importantly, however, SUPERCHANGER units do a more efficient job of transferring heat in most applications,

due in large measure to the turbulent flow created by the corrugated patterns of their plates.

For a side-by-side comparison between SUPERCHANGER plate and frame heat exchangers and shell-and-tube exchangers, the charts below show the difference in dimensions and comparative performance data for two units in an identical application.

SUPERCHANGER®

PLATE AND FRAME HEAT EXCHANGER

SHELL-AND-TUBE HEAT EXCHANGER

■ High efficiency—"U" values 3 to 5 times greater than shell-and-tube; often greater than 1,000 Btu/ft. ² hr.°F	■ Low efficiency
■ Uses only 10% to 50% of shell-and-tube space	■ Needs twice as much space to pull tube bundle
■ Easy disassembly—just loosen bolts	■ Complex disassembly—tube bundle must be pulled
■ Lower cost when stainless steel or higher grade of material is required	■ Higher cost except in all carbon steel construction
■ Low fouling due to corrugations and inherent turbulence	■ High fouling due to circular cross-section and channeling—approximately 10 times greater
■ Variable heat transfer surface—plates easily added or removed	■ Fixed surface only
■ Low weight—typically 1/6th of shell-and-tube	■ High weight—up to 6 times that of plate and frame
■ Intermix between fluids impossible due to gasket design	■ Fluids can intermix, both at welds and at tube sheet
■ Inspection—simply disassemble and inspect	■ Inspection difficult—must usually pull tube bundle
■ Excellent chemical cleaning due to corrugations/turbulence	■ Satisfactory chemical cleaning but must be cautious of dead spots
■ Maximum viscosity—30,000 cps Nominal	■ Maximum viscosity—10,000 cps
■ Pressure drop—low to medium	■ Pressure drop—low to medium
■ Practically no heat loss—no insulation required	■ Great amount of heat loss—insulation required
■ Can be designed for less than 2°F temperature approach with more than 90% heat recovery attainable	■ Typically only a 5°F to 10°F minimum temperature approach can be achieved
■ Computer custom-designed sizing per application	■ Computer designed, but must always be oversized to be safe
■ Low internal volume—10% to 20% of shell-and-tube	■ Very high internal volume
■ Multiple duties possible with connecting frames	■ One unit required for each duty

TYPICAL UNITS DESIGNED FOR THE SAME HEAT TRANSFER CONDITIONS

ITEM	SUPERCHANGER	SHELL-AND-TUBE
Surface Area	1,000 sq. ft.	3,000 sq. ft.
Total Length Required	86"	157"
Width	32" Diameter	30" Diameter
Height	84"	42"
Gross Volume	18 ft. ³	116 ft. ³
Net Weight	1,600 lbs.	6,000 lbs.

Plate and frame heat exchangers take as little as one-tenth the space required for shell-and-tube exchangers, particularly when considering the space required for tube removal.

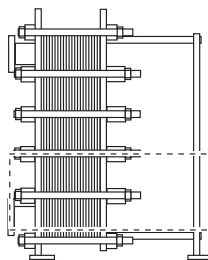

DOTTED LINE REPRESENTS SPACE REQUIRED FOR TUBE REMOVAL

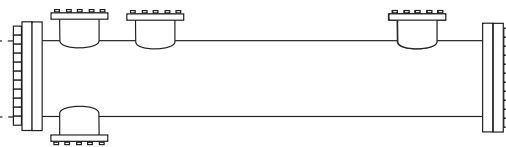

REPRESENTED BY:

For further information on PLATECOIL prime surface heat exchangers and SUPERCHANGER plate and frame heat exchangers, contact:

TRANTER, inc., Texas Division • P.O. Box 2289
Wichita Falls, Texas 76307 • (940) 723-7125
Fax: (940) 723-5131 • <http://www.tranter.com>

